

# **IEE** JOURNAL

VOL. 23 NO. 1 JUNE 1983  
M. C (P) 77/6/83  
ISSN 0377-7464

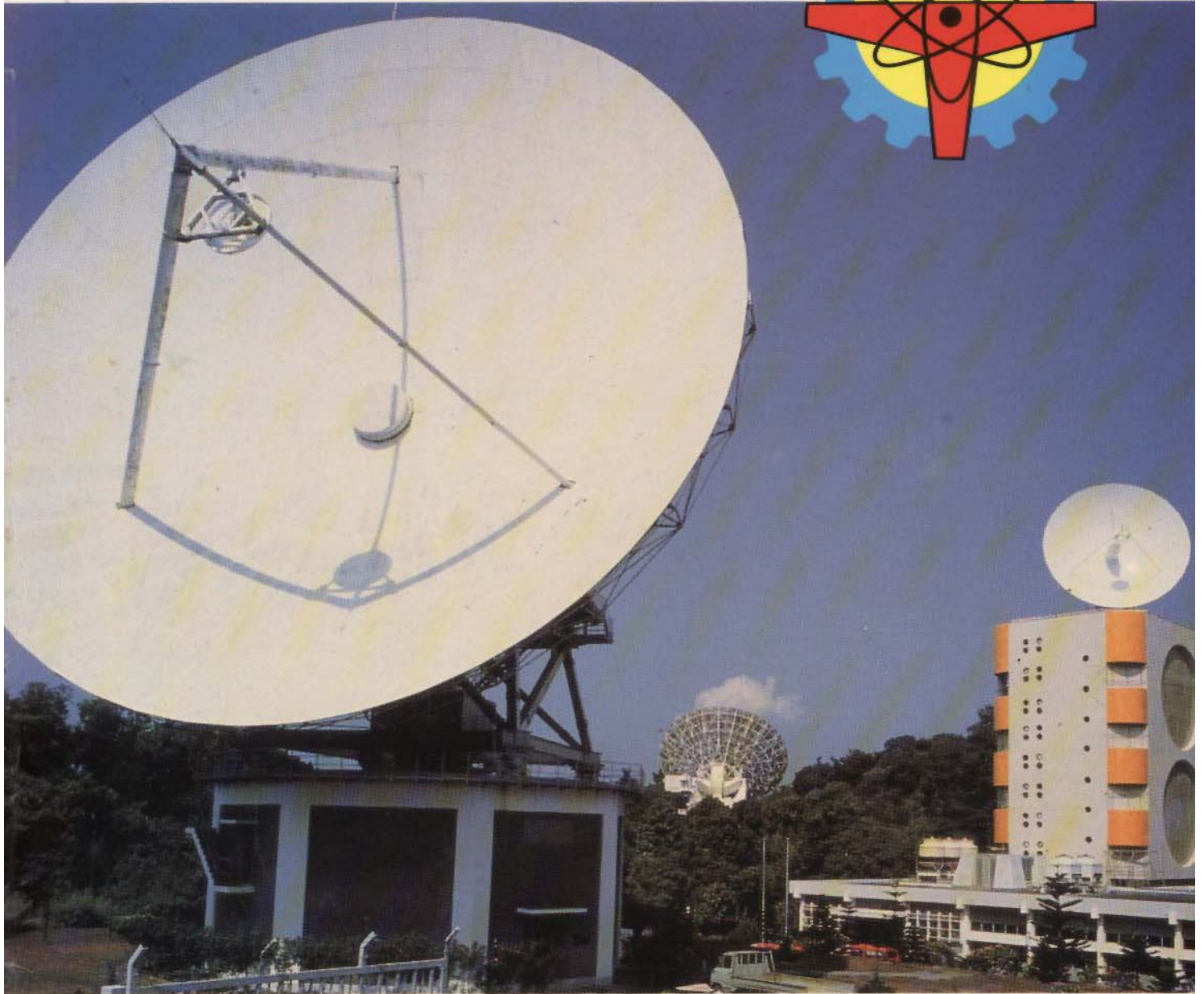

**THE INSTITUTION OF ENGINEERS, SINGAPORE**

10, Anson Road #14-06 International Plaza, Singapore 0207.

# CONTENTS

---

Editorial .....	3
Members Statistics .....	4
IES Committees for 1982/1983 .....	5
Geological Considerations in Excavation and Foundation Design .....	9
Design and Analysis of Industrial Safety Tests: An Application to Hand-Held Grass-Cutters .....	19
Construction of Dykes in Bintulu Deep Water Port .....	31
Odorousness of Sewage Air .....	49
Finite Elements for the Practising Engineer .....	57
Diaphragm Wall Construction in Stiff Soil – A Case Study .....	75
Present Worth of Energy Savings .....	89

## COVER PHOTO:

### GLOBAL MARITIME SATELLITE COMMUNICATIONS VIA SINGAPORE COAST EARTH STATION

*Nestled between the existing mighty dishes of the Intelsat system, Singapore's colourful coast earth station (CES) was commissioned by the Telecommunication Authority of Singapore on November 1, 1982. This CES operates towards the Pacific Ocean Region satellite of the INMARSAT (International Maritime Satellite Organisation) system. This is the first maritime satellite coast earth station in South East Asia and it is intended to handle the ship-to-shore, shore-to-ship and ship to ship telex, telegram, telephone, data and telefax calls of the maritime community in Singapore as well as in the SEA region.*

*Courtesy of Telecommunications Authority of Singapore.*



# FINITE ELEMENTS FOR THE PRACTISING ENGINEER

**N KRISHNAMURTHY, MIES**  
Associate Professor  
**Department of Civil Engineering**  
**National University of Singapore**

## ABSTRACT

The increasing use of computers in Singapore makes it imperative for engineers to understand the power as well as the limitations of the finite element method. The paper describes the basic principles of the method and discusses its advantages, fields of application, and the potential dangers of its misuse.

## INTRODUCTION

Finite element method is a relatively recent computer-based technique of structural and stress analysis that has become a very powerful and popular tool within the last twenty to twenty-five years.

In this short period, scores of books, hundreds of reports, and thousands of papers have been published on the principles and applications of the method. The reasons for its popularity are its versatility and power; but the reason for its quick growth is the phenomenal development of digital computers.

Because of the suddenness with which the finite element method appeared on the engineering scene, and the speed with which it has grown in certain parts of the world, those practising engineers in other parts of the world, who have not had the benefit of computer training as well as finite element background, have been "left behind", in a sense.

Many such engineers have learnt to use specific computer programs, but it would be dangerous to use finite element programs without knowing their strengths and weaknesses, and without understanding the consequences of improper modelling of real-life problems.

The principles involved, the terminology used and the skills needed for finite element analysis are often so different from their classical engineering counterparts, that it is also not easy for a practising engineer who has not had a formal course in the subject, to study independently and catch up with the still advancing state of the art in finite elements.

But civil, mechanical and other engineers must learn the art and science of finite elements, and the sooner the better. The method is here to stay; to be fair, it is by far the most general, the most powerful, the most efficient, the most precise, and in actual application (as contrasted with its theoretical aspects) the simplest of investigative, analytical and design tools available today, especially for the complicated situations that modern engineering and technology involve.

In this paper, the author presents the basics of the finite element method in simple, non-mathematical terms, discusses its advantages and dangers, and hopes to share his experience of over fifteen years with teaching the subject, and with using the method in his research and consulting. The twin objectives of the presentation would be to convince the skeptic of the power of the method, and to caution the zealot of its perils.

## 2. PRINCIPLE

The idea itself is not new. All of us who have had to analyse an arch with varying cross-section as in Fig. 1(a), have always divided it into a certain number of segments, each assumed straight and prismatic, as in Fig. 1(b). The continuously curved non-prismatic structure would thus be “discretised” or “idealised” into a certain limited number of segments of known behaviour patterns.

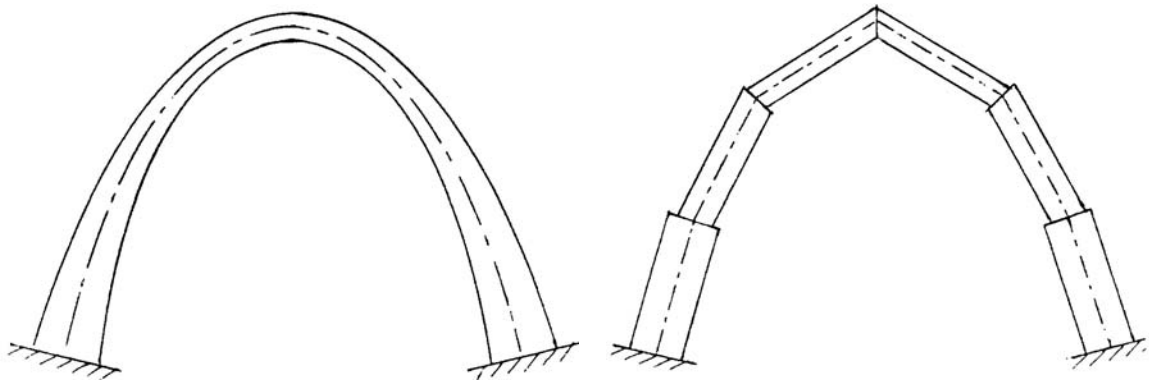

Fig. 1 Discretisation of a Non-Prismatic Arch

There would exist a set of relationships between the forces and displacements at the two supports and the intermediate junctions between the segments. On assembly of these relationships, enough simultaneous equations would be developed to solve for the unknowns.

We know this is only an approximation. But we also know that almost everything in engineering, including foundation characteristics, material properties, loading conditions etc. are all approximations to some degree. Further we also know that a lot of the approximations can be improved by special techniques.

For example, in the arch problem, we can improve the theoretical basis by developing the force-displacement relationship for a circularly curved segment, and use it instead of the straight segment relationship. We can also subdivide the arch into a large number of segments (straight or curved), and asymptotically approach the original arch geometry – although at considerable additional computational effort and time, which of course usually translates into money.

The same technique can be adopted for “continua”, that is structures or systems that cannot be idealised by lines, but consist of solids which at best can be represented as planes.

Thus if we had an odd-shaped plate with a circular hole in it, supported at certain points around its edge, and subjected to some in-plane forces  $A_1, A_2, \dots$ , as in Fig. 2(a), there is no way we could solve for the stresses and deformations in it by any classical method.

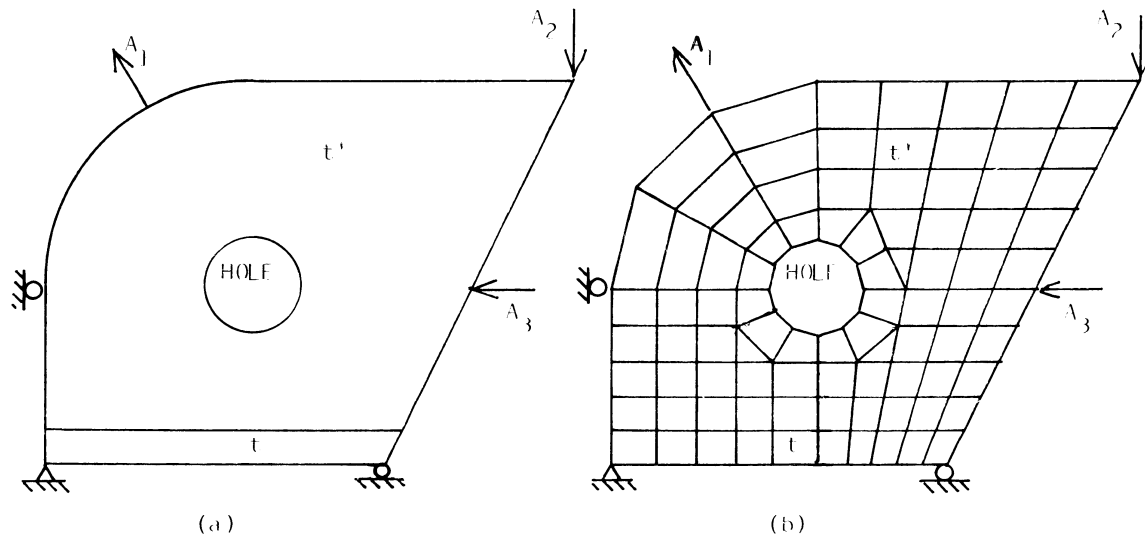

**Fig. 2 Plate With Hole, and Finite Element Idealisation;  $t$  and  $t'$  are Different Thicknesses**

But we could divide the plate into a finite number of pieces, or “elements” (as against the infinite number of particles it comprises— and hence the term “finite elements”), as shown in Fig. 2(b), and analyse the plate as an assemblage of the elements. The elements could be of any convenient simple shape such as the triangle or the Quadrilateral, and would be considered to be connected to one another or to supports, only by the corners or at other reference points along their edges, such connection points being termed “nodes”

### 3. DISPLACEMENT FORMULATION

The simultaneous equations governing the behaviour of structures or continua may be formed on the assumption that some quantity is the primary unknown. In frame analysis, there are two broad options namely the “stiffness method” in which the displacements (deflections or rotations) are the primary unknowns, and the “flexibility method” in which the redundant actions (forces or moments) are the primary unknowns. In the finite element method, the analog of the former, namely where the nodal displacements are the primary unknowns, is the more common because of the ease of formulation and convenience for computerisation.

In both frame (or truss) analysis and finite element analysis, the reference directions for various possible forces and moments (and corresponding deflections and rotations) at the joints or nodes are called “degrees of freedom”, and abbreviated to “DOF”. The beam element of Fig. 3(a), able to take only shear and moment at any section, has two DOF per joint, and four DOF for both ends of the member. The actions are marked  $A_1, A_2, A_3, A_4$  and the corresponding displacements are denoted  $D_1, D_2, D_3, D_4$ . Likewise, the straight segment of the arch (or of any plane frame for that matter), has horizontal, vertical, and rotational – or equivalent axial, transverse, and rotational – DOF at each end, totalling to six DOF, marked 1,

2, ..., 6 in Fig. 3(b), for the member. A plane triangular element subject to horizontal and vertical forces or deflections at each vertex as in Fig. 3(c) has two DOF per node for all three nodes, or six DOF.

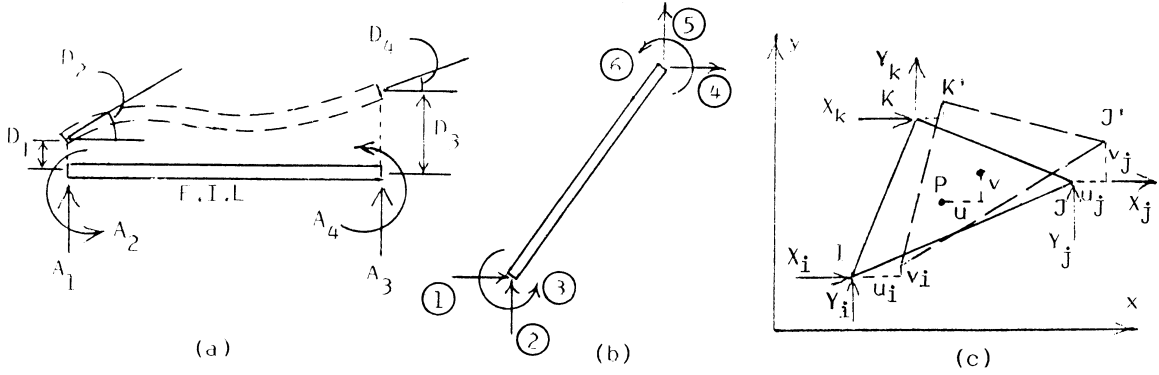

**Fig. 3 Degrees of Freedom for (a) Beam, (b) Frame Member, and (c) Plane Triangle**

In general the action at any DOF of an element is a function of the displacements at all the DOF for the element. For instance, in the beam of Fig. 3(a), we have, from classical structural theory, (8),

$$\begin{aligned}
 A_1 &= C_1 D_1 + C_2 D_2 - C_1 D_3 + C_2 D_4 \\
 A_2 &= C_2 D_1 + C_3 D_2 - C_2 D_3 + C_4 D_4 \\
 A_3 &= -C_1 D_1 - C_2 D_2 + C_1 D_3 - C_2 D_4 \\
 A_4 &= C_2 D_1 + C_4 D_2 - C_2 D_3 + C_3 D_4 \quad \dots (1)
 \end{aligned}$$

where,  $C_1 = 12EI/L^3$ ,  $C_2 = 6EI/L^2$ ,  $C_3 = 4EI/L$ , and  $C_4 = 2EI/L$ , with  $E$  being Young's Modulus of Elasticity, and  $I$  and  $L$  being the moment of inertia and length of the beam.

All the four simultaneous equations in Eq. (1) may be compactly represented in matrix form as:

$$\{A\}_m = [K]_m \{D\}_m \quad \dots (2)$$

in which,

$$\begin{aligned}
 \{A\} &= \{A_1, A_2, A_3, A_4\}, \\
 \{D\} &= \{D_1, D_2, D_3, D_4\}, \\
 [K] &= \begin{bmatrix} C_1 & C_2 & -C_1 & C_2 \\ C_2 & C_3 & -C_2 & C_4 \\ -C_1 & -C_2 & C_1 & -C_2 \\ C_2 & C_4 & -C_2 & C_3 \end{bmatrix} \quad \dots (3)
 \end{aligned}$$

and the subscript m, refers to the member of element.

It may be noted in passing that all stiffness matrices will be square and symmetric about the diagonal.

When a number of beam segments or elements A, B, ..., are assembled to form a continuous beam as in Fig. 4, the individual stiffness relationships,

$$\begin{aligned} \{A\}_a &= [K]_a \{D\}_a \\ \{A\}_b &= [K]_b \{D\}_b \quad \dots (4) \\ &\dots \text{ etc.} \end{aligned}$$

get "coupled" in the sense that actions corresponding to the common DOF add, and displacements corresponding to the common DOF are equal.

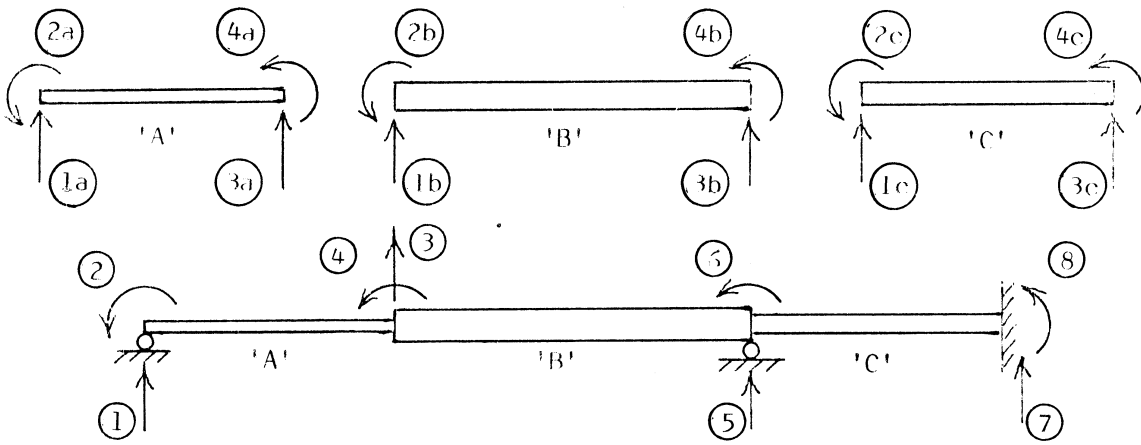

Fig. 4 Continuous Beam Assembled from Three Members

For instance, from element A, and the third of Eq. (1), we have:

$$A_{3a} = -C_{1a} D_{1a} - C_{2a} D_{2a} + C_{1a} D_{3a} - C_{2a} D_{4a} \quad \dots (5)$$

and from element B, and the first of Eq. (1), we have:

$$A_{1b} = C_{1b} D_{1b} + C_{2b} D_{2b} - C_{1b} D_{3b} + C_{2b} D_{4b} \quad \dots (6)$$

But as 3a and 1b refer to the same DOF number 3 on the structure, equilibrium of forces requires,

$$A_3 = A_{3a} + A_{1b} \quad \dots (7)$$

and compatibility of displacements requires,

$$\begin{aligned}
 D_1 &= D_{1a} \\
 D_2 &= D_{2a} \\
 D_3 &= D_{3a} = D_{1b} \\
 D_4 &= D_{4a} = D_{2b} \\
 D_5 &= D_{3b} \\
 D_6 &= D_{4b} \quad \dots \dots (8)
 \end{aligned}$$

On substitution of Eq. (8) into Eqs. (5) and (6), and of the result into Eq. (7), we get,

$$A_3 = -C_{1a} D_1 - C_{2a} D_2 + (C_{1a} + C_{1b}) D_3 - (C_{2a} - C_{2b}) D_4 - C_{1b} D_5 + C_{2b} D_6 \quad \dots \dots (9)$$

Similar relationships may be written for all the DOF in the structure or system, and expressed in matrix form as:

$$\{A\} = [K] \{D\} \quad \dots \dots (10)$$

where the absence of subscripts denotes that the matrix equation refers to the entire system.

For a system with  $n$  DOF, Eq. (10) consists of  $n$  simultaneous equations relating actions  $A_1, A_2, \dots, A_n$  to displacements  $D_1, D_2, \dots, D_n$ .

In the continuous beam problem of Fig. 4 with a total of 8 DOF, displacements at the supported DOF, such as  $D_1, D_5, D_7$ , and  $D_8$  are known, and so are the applied actions along the unsupported DOF, namely  $A_2, A_3, A_4$ , and  $A_6$ . The incorporation of the known displacements and the solution for the unknown displacements in Eq. (10) follow standard procedures, and are very elegantly carried out on digital computers. We will not pursue that aspect of the analysis further.

It must be reiterated however that the stiffness method or displacement formulation outlined here is precisely what preceding generations of structural engineers have known and used as the Slope Deflection Method. Matrix algebra only made the organisation and manipulation of the numbers more efficient, and the computer simply enabled much larger problems to be solved, faster and more accurately than before.

In the preceding development, once the beam stiffness matrix Eq. (3) became available, the subsequent steps of the assembly of structure stiffness matrix and of the solution, are very general and independent of the nature of the structure.

Exactly the same arguments and procedures would apply to any other structure such as a truss or a frame, and, in fact to any other plate, shell, solid or other supported and loaded system which may be considered to be composed of separate elements. Thus, once frame analysis by matrix computer methods has been understood, the transition to finite element analysis should be relatively easy.



## 5. FINITE ELEMENT STIFFNESS

The transition to finite elements would be trivial in fact, if the stiffness matrix for a general finite element could be developed from fundamental principles.

In the case of “line elements” such as beam segments and truss members, the stiffness coefficients such as  $C_1, C_2, \dots$  in Eq. (1) could be rigorously derived from classical strength of materials. But in case of a “continuum element” such as a triangle or quadrilateral in Fig. 2(b), the action-displacement behaviour cannot be quantified from principles of continuum mechanics; the one possible exception would be a rectangle of constant thickness, but this alone would not be of much use.

It is interesting to trace how the development of digital computers served to catalyse the development of finite element theory. In pre-computer times, the analysis of frames and other “discrete” structures (consisting of line elements) was usually limited to a few unknowns, either by a wise choice of the solution technique, or by the use of approximations, so as to keep the solution to within manually manageable limits. Even for very large structures such as the Empire State Building in New York, iterative methods such as moment distribution sufficed to avoid solution of simultaneous equations in too many unknowns. At that time, any research or development in the area of finite element analysis was purely an academic exercise. Two rectangles set together would result in six nodes, and even with two DOF per node, there would be twelve simultaneous equations! There was thus no practical incentive to think about the stiffness matrices of continuum elements.

All these changed with the debut of the digital computer into the engineering scene in the fifties. Suddenly, the number of simultaneous equations to be solved was no more a problem. Very soon, hundreds of simultaneous equations could be solved within minutes. (Today, thousands can be solved in a much shorter time.) Almost immediately, there was a push to develop the finite element capabilities to take full advantage of the new computational power that became available. The pursuit of finite element stiffness matrices became a “gold rush”.

While it became clear that no “exact” governing equations could be generated for general finite element shapes from classical mechanics, investigators were quick and daring enough to make assumptions on displacement or stress variations (or “fields”) over simple element shapes, based on their theoretical knowledge and practical experience, (10).

For instance, the simplest logical assumption for the displacement field over a triangle IJK under plane loading as in Fig. 3(c), will be that the displacement of any general point P varies as a linear function of its x' and y coordinates:

$$\begin{aligned} u &= ax + by + c \\ v &= dx + ey + f \end{aligned} \quad (11)$$

in which, u and v are the displacements parallel to the x and y axes, and a, b, ..., f are coefficients called “displacement functions”.

By application of Eq. (11) to the nodes I, J and K, and solution of the unknown coefficients a, b, ..., f in terms of the nodal coordinates  $x_i, y_i, \dots$ , we can write the general displacement as functions of the nodal displacements  $u_i, v_i, \dots$ , as:

$$N_1 v_1 + N_2 v_2 + N_3 v_3$$

in which  $N_i, N_j, \dots$ , are known as “shape functions”, involving the shape or geometry of the element.

In due course, very interesting techniques were developed to generate shape functions directly, rather than start with displacement functions.

Beyond the shape function, the mathematics gets a little tricky—not complicated, but somewhat tedious and requiring a background of advanced calculus and matrix algebra. We will not try to develop the formulas further, but only trace the logic of the subsequent steps, (10).

The external work done on the element by the nodal forces such as  $X_i, Y_i, \dots$ , in Fig.3(c) involves the sum of the products of the applied forces and the corresponding nodal displacement components.

The internal strain energy stored in the elements involves the sum of the products of the strains and stresses in an infinitesimal volume of the element, integrated over the entire region of the element. In simple cases such as with Eq. (11), the integration may be carried out explicitly, but in the more complicated cases, the integrals must be evaluated numerically.

Now, strains are first derivatives of the displacements. In the simple case of the linear displacement functions represented by Eq. (11), the first derivatives of  $u$  and  $v$  with respect to  $x$  or  $y$  are all constants, that is, the normal and shear strains are constants. In fact for this reason, the six DOF triangle is known as the “Constant Strain Triangle” or “CST” for short. With the use of shape functions such as Eq. (12), strains may be written in terms of nodal displacements.

Stresses are related to strains through the material properties such as Young’s Modulus of Elasticity and Poisson’s Ratio, and thus the stresses also become functions of the internal displacements and hence of the nodal displacements.

Thus, the strain energy can be finally reduced to expressions involving the element geometry, material properties, and nodal displacements.

If now the external work and internal energy are equated, and some cute algebraic tricks are performed, we can manage to get the stiffness matrix for the element as functions of the element dimensions and material properties, in the same form as before:

$$\{A\}_m = [K]_m \cdot \{D\}_m$$

As an example, the first term of the element stiffness matrix for a CST will be:

$$K_{11} = Et[(y_j - y_k)^2 + (x_k - x_j)^2 (1-p)/2] / [4T(1-p^2)] \quad (13)$$

where  $p$  is Poisson’s Ratio, and  $t$  and  $T$  are thickness and area of the triangle. (The other terms are equally bad or worse!)

After the general methodology was developed on the basis of the CST, investigators used considerable intuition, imagination and ingenuity to develop stiffness matrices for other shapes such as the rectangle and quadrilateral in plane stress or plane strain: and extend their use to axisymmetric solids, and to develop three-dimensional elements such as the tetrahedron (pyramid) and the parallelepiped (six-sided block). Nodes located on the edges

and/or on the faces of the element, between the corners, permitted curved boundaries and more elaborate shape functions, leading to better stress representations. Plate bending elements, shell elements, etc. soon followed. Figure 5 shows some typical elements.

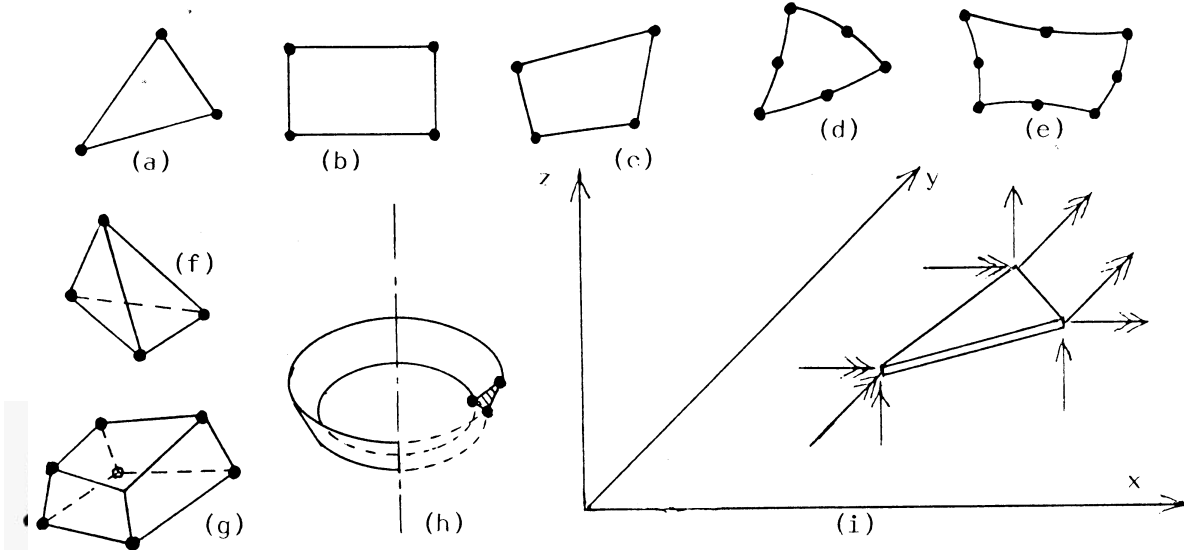

**Fig. 5 (a) to (e) Plane Elements; (f) and (g) Solid Elements; (h) Axisymmetric Element; (i) Plate Bending Element. (Double Arrowheads are Rotational DOF.)**

Many early investigators did pioneering work and kept coming up with newer and better elements. Their contemporaries and a few succeeding generations of post-graduate students got Ph.D.-s for refining existing elements and proposing fresh elements. By the late sixties however, the technique had become so commonplace that most further developments rated only master's degrees. Almost all the efficient stiffness matrices for different kinds of elements are available from books(2, 3, 10)and reports. Even today, marginal improvements in finite element stiffnesses are being pursued, but with the findings only being published in the technical journals.

Needless to say, the actual development of a "good" stiffness matrix requires considerable sophistication and skill. But practising engineers and others among us who just want to use the finite element method (and not advance the state of the art in the theory!) do not need to bother about the derivation of stiffness matrices. Instead we can treat them like the latest cameras: they are available, they do a lot of useful things and give us a lot of satisfaction, without our knowing how exactly they get the exposure and even the focus right. But of course, we must know how to *use* them right!

## 6. APPLICATIONS

As soon as the CST "hit the streets" and became public knowledge in the late fifties, research and development engineers started applying the method, first to aeronautical structures such as wings and fuselages, and then to civil engineering structures such as dams and tunnels. As more and more elements were developed, and simultaneously bigger and faster computers became available, there was an information explosion on the finite element method, and a feverish (if not mad) scramble to apply it to all kinds of practical problems. In fact, the method actually created the demand for more applications, - a solution looking for problems, so to speak.

In the last two decades or so since the method first became popular, thousands of papers and hundreds of reports have been published and presented, on the applications of the method, and this is just the beginning. One cannot open a book or a journal, or attend any conference, in civil, mechanical, materials, aerospace, automobile, and many other engineering disciplines, without running smack into it. From a researcher's plaything, the method has become the standard analytical and design tool for construction, manufacturing and testing organisations, and has also invaded government public works departments.

To give it its due, the method is more than a passing fad or popular craze. It has opened up a whole new world of analysis, design, testing, and simulation. Because the method is applicable with nearly equal ease and validity to any geometry, material, support, and loading combinations and variations, it is enabling investigators not only to take a fresh look into existing theories (and end up disproving or at least modifying them as soon as confirm them), but also to venture into completely new, uncharted territory.

It would be an impossible task to even list all the applications of the method. To make a general statement, it is equally at home in:

- static and dynamic analysis;
- concentrated and distributed loading;
- gravity and magnetic fields;
- linear and nonlinear analysis;
- elastic, elasto-plastic, visco-elastic, and plastic analysis;
- creep and thermal analysis;
- instability and crack propagation;
- homogeneous, layered, and heterogeneous media;
- isotropic, orthotropic, and anisotropic materials;
- .. etc. etc.

The method has been applied extensively to foundations, shear wall buildings, and shell roofs, and to bridges of novel design, expanding the freedom of the architect and the power of the designer by many orders of magnitude, (2, 10). It has been used, by the author among others, to analyse things as small as the human tooth (Fig. 6), (9), and as large as the nuclear reactor (Fig. 7), (1). Ships on the high seas, and rockets to the moon have been designed by it. Car bodies are safer, and turbines run better, because of it.

Its applications do not stop with structural and stress analysis. The same technique of establishment of governing relationships for a general element, discretisation of the region into many finite elements, and computer assembly and solution of the resulting simultaneous equations, has been applied to heat and sound, to fluid and gaseous flows, as well as to their interactions with each other and with solids, (2, 3, 10). So there are innumerable other applications from non-structural mechanics fields: pumping of blood by the heart, dispersion of effluents at tidal basins, thermal inversion due to atmospheric pollutants – you name it, and

chances are that it has already been analysed by the finite element method.

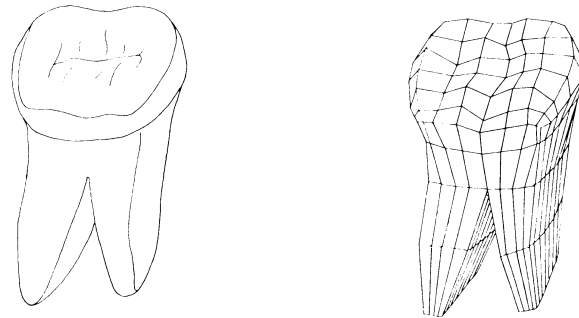

**Fig. 6 Finite Element Modelling of Human Tooth**

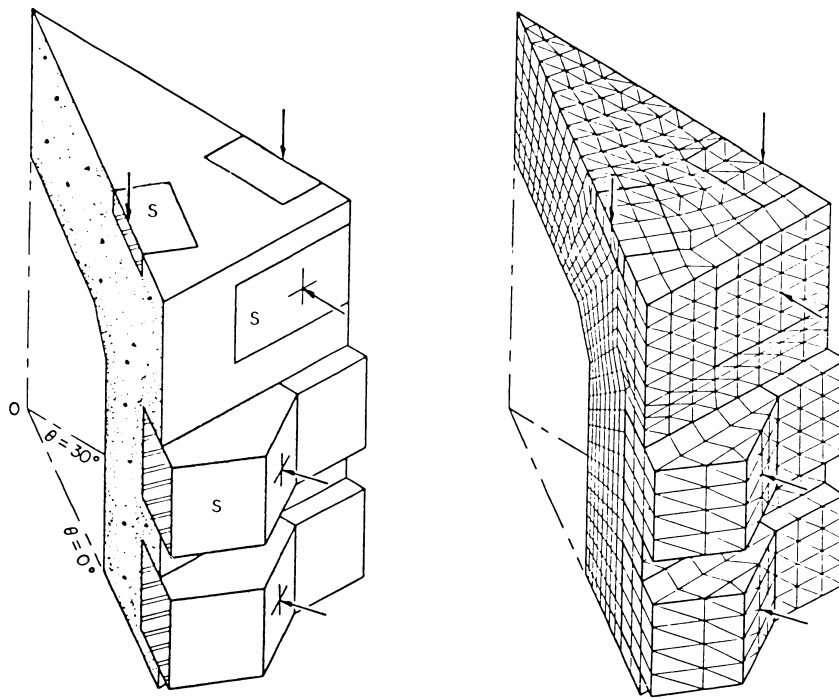

**Fig. 7 Finite Element Modelling of One-Twelfth Symmetry Segment of Top Half of Prestressed Concrete Nuclear Reactor Model. (s = steel)**

An aspect which bears reiteration is the ability of the method to simulate entire phenomena as against a single situation for analysis. Events can be made to happen inside the computer in the order and manner in which they actually take place in real life. Combined with its capability to cover macroscopically large domains as well as enter into microscopically small details, an investigator can discover a lot that was not known before, about the behaviour of many engineering operations on which much had been assumed. The author applied such simulation to the process of pretensioning bolted connections and then subjecting them to external loading, and discovered that the “prying forces” that had been postulated to be present in such connections were not at all critical, (5, 6, 7). As a result of this simulation applied to parameter studies, he was able to propose a design procedure for a particular (“end-plate”) connection that saved about 40 percent in material and related labour, (5).

## 7. PROBLEMS AND PITFALLS

Now for the bad news. Before we get too carried away by the awesome power and exciting potential of the finite element method, it is appropriate to look at the few but critical dangers of possible misunderstanding or misuse of the method.

There are basically two major sources of problems in the application of the method, especially in the use of a finite element program by the novice. (We will assume that the program and input data are completely error-free, and that the computer capacity and precision are adequate.)

The first problem is in the very nature of the finite element method, namely the approximations used in the development of the element stiffness. No element can be all things to all people, no element can represent all possible behaviour patterns equally well; compensation in one aspect often causes distortion of another. The ideal model of anything is itself; and nature is too complex, too devious, to be so strait-jacketed by scientists. What it all adds up to is that we should know what a particular element is capable of, and must not expect more from it.

Thus, for instance, we might run a plane stress analysis with 500 CST elements, and still not get as accurate answers as another run with 100 elements more refined, as indicated in Fig. 8. Further, if we did not know what element we were using, and tried doubling the number of CST elements to 1000, we might get a new answer sufficiently close to (say within a few percent of) the earlier one, so that we would be fooled into thinking we were getting close to the "exact" value, while it might actually be worse than the result from the coarser mesh of more refined elements! On the other hand, doubling the number of refined elements to only 200 would get

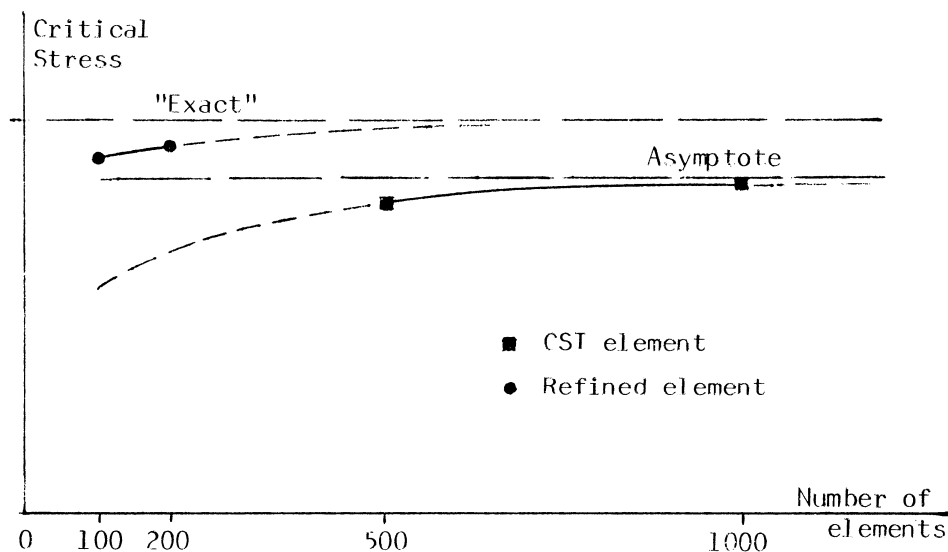

Fig. 8 Convergence Capabilities of Different Elements

us even closer to the exact value. In short, apparent, asymptotic convergence is no test of absolute accuracy of the solution. An element cannot represent certain situations any better. In the example of photography cited earlier, one limitation could be the resolution of the lens, so that, whatever fine grain film or special processing we used, the particular lens just would not give any better enlargements beyond a certain limit.

The second difficulty is even more insidious. We might give the same program and the same frame problem to half a dozen structural engineers, and they would all get the same answer, or if there were some judgement involved (as with non-prismatic members or nonlinear loading patterns) answers differing only slightly from one another.

But if we gave the same finite element program and the same continuum problem to the six engineers, chances are we would get six different sets of maximum displacements and stresses. The range, in complicated situations, could be 100 percent variation or more! Who would be right? Perhaps none.

The trouble is, finite element is as much an art as a science. In a sense, two different solutions by a finite element program may be likened to different designs by two engineers. But unlike the two designs, one or both the finite element solutions may not be safe.

The major variable in finite element analysis is the mesh, implying both the number of elements, as well as their distribution. It is well known that the finer the mesh, the better the answer. But finer meshes involve more input data, the preparation of which will get more and more tedious, time-consuming, and (most importantly) error-prone. If a large number of problems of the same kind must be solved, a good tactic is to write a "pre-processor" which, with the input of a few key dimensions and the number of divisions along different directions in various regions, would automatically generate the node and element data for the finite element program in the sequence and format needed.

But how fine a mesh is fine enough? Ideally, one should start with a good element that would represent the anticipated behaviour well, and analyse the problem with two or more meshes, so that the progressive improvement of critical values would not only give an indication of the relative precision of the meshes, but also provide enough information to extrapolate to a better estimate.

While this sounds straight-forward enough, it is very rarely possible in real situations. Computer resources are expensive; moreover, however big the computer, there are limits to the number of simultaneous equations it can solve in a reasonable time, and to within a certain accuracy. Except perhaps in universities where the pursuit of truth may outweigh costs, and in space and other research organisations in which concern for human safety is paramount, computer costs set a realistic ceiling over our ambitions on one good mesh, let alone on a series of meshes.

Nodes and elements thus become like dollars in our bank accounts. Judiciously used, the rewards are great. Misused, we may not only get nothing, but also get into trouble! All six answers from our panel of engineers could well be to the same impressive number of decimal places from the same giant mainframe computer, but there would be no guarantee anyone of them was sufficiently close to the correct value.

The author can present one of the examples from his experience where this situation was dramatised, (4). The U.S. Atomic Energy Commission wished to determine the maximum stress in a nuclear pipe-nozzle junction; the author did a three-dimensional finite element study on it, with three different meshes, consisting of 504, 1170, and 2112 nodes. (The number of simultaneous equations were three times the number of nodes in each case.) Iso-stress lines of the critical circumferential ("hoop") stress across the longitudinal section were plotted for each case, as shown in Fig. 9. The maximum stress, at the inner corner, may be seen to be about 5000, 6000, and 6500 psi (lbs. per sq. in.), that is, 34500, 41400, and 44800 kN/m<sup>2</sup> respectively, a range of variation of 23 percent with respect to the largest value, vividly

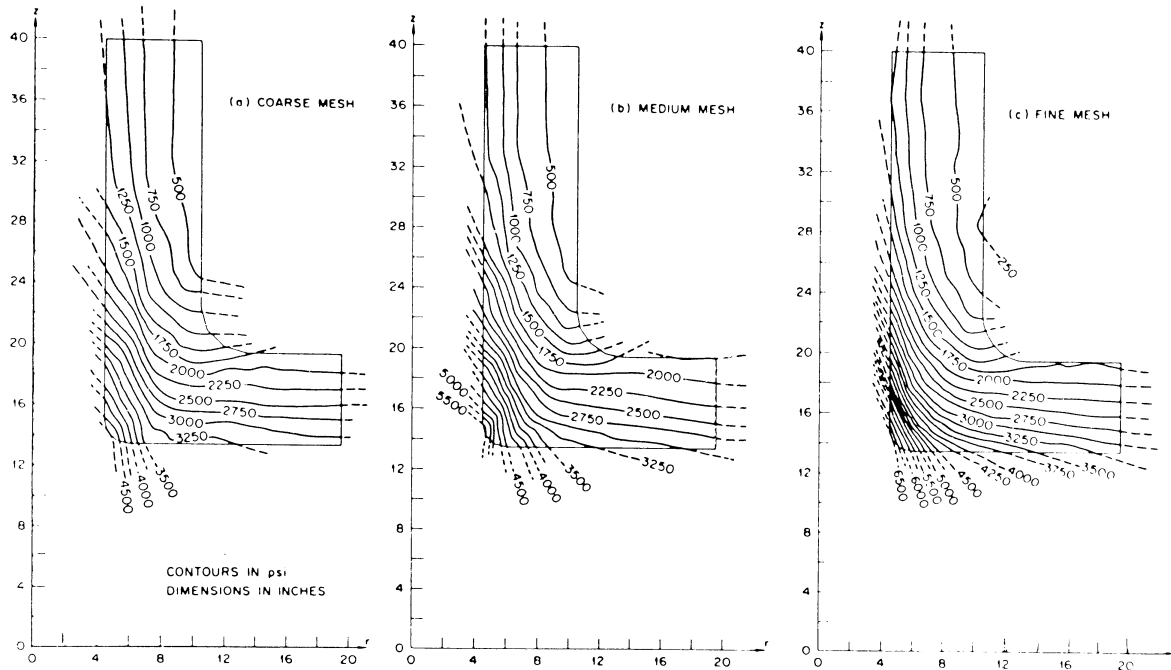

**Fig. 9 Effect of Mesh on Stress Concentration in Pipe-Nozzle Junction**

demonstrating the mesh effect. Not content to take the value of 6500 psi from the finest mesh (8 percent away from the medium mesh value), the author did some fancy extrapolation, and worked out the result for the continuum (namely for infinite number of elements) as 6700 psi or 46200 kN/m<sup>2</sup>.

It is obvious in this example, that if computer resources had limited the analysis to the coarse mesh, the result would have been an underestimate of at least 25 percent below the best prediction. How could anyone have foreseen (at the time) that it would take a mesh of more than 6000 DOF, running longer than three hours CPU (Centre Processing Unit) – actual time all night – on an IBM 360/65, to achieve a solution that would come to within 3 percent of the estimated “exact” value for the continuum?

Incidentally, a lot of preliminary study had gone into the pipe-nozzle analysis. The final meshes chosen reflected the knowledge gained from the earlier studies, such as the effectiveness of more elements being crowded around the bend than in the straights. Without such preliminary studies, without results from three meshes to extrapolate from, or alternatively, without the benefit of similar experience earlier, the finite element analysis would not have been of any practical value.

The photographic analogy for this situation would be the portrait of an unknown person with an untested close-up lens, from which one could not tell if the bulging nose was the way it was, or the result of distortion by the lens. Indeed, if for a complicated problem any one offered the result from a single mesh without being able to back it up with other evidence or credible experience, we would be well advised to take out a lot of insurance!

There are other trouble-spots such as “aspect-ratio” of the longer to smaller dimension of



elements, and element “bias” as with triangular elements. However, these are easier to guard against than the problem of the proper mesh size and distribution.

Apart from the difficulties already referred to, finite element analysis involves more decisions in the reduction of a physical problem to a computer model, than almost any other engineering analysis. Can a two-dimensional analysis adequately represent the behaviour of a system that should be ideally investigated by the much more expensive three-dimensional analysis? Should the total system be analysed (– in fact, what is the total system? –), or can we get away with the analysis of just the portion judged critical? If the latter, what boundary or loading conditions should be assumed at the interface? Finite element modelling, including the mesh layout, is where expertise would be most needed, and where lack of experience could lead to the direst consequences.

Evidence of the lack of guidelines in the matter and of the difficulty of developing such guidelines may be seen in the fact that a committee of experts of the American Society of Civil Engineers has laboured for two years, and only now completed the first draft of a review of finite element modelling problems and a list of suggestions (not rules!) to detect and alleviate them.

So how does a newcomer get a head-start? Personal experience is a slow and long road. Learning from, or working with a ‘guru’, an experienced master, would be a good way to start. If possible, for complex problems where no prior experience is available, various meshes (with different sizes and distribution) must be tried and the results extrapolated to get the best estimate. A simplified version of the problem, for which some kind of solution or expertise already exists, may be analysed with a certain mesh, and the results compared – in the hope that the complex problem with an analogous mesh would not fare much worse.

Existing analytical or experimental results on similar problems would provide a basis for the evaluation of finite element results. But here, an interesting situation may develop: the finite element results may not be necessarily wrong if their agreement with analytical or test results is not perfect. On the other hand, perfect agreement of a finite element solution with a particular theory or test may itself be suspicious. It sounds paradoxical, but once a finite element has certain basic capabilities, its use in a well conducted analysis could present a truer picture of the actual behaviour than theories based on certain simplifying approximations or tests susceptible to experimental and human errors. A case in point is in the analysis of a short-span ‘I’ beam: The simple theory of bending, likely to be used for the evaluation, ignores shear deformations and shear lag. But a 3D finite element analysis, not inhibited by the assumptions of the theory, would give better answers which however would disagree with the theoretical results.

Finally, when all the decisions are made and all the analysis is done, there remains one last problem: namely the interpretation of the output. Even frame analysis of a multi-storey building would produce a stack of output, but all the numbers would be meaningful, directly useful – so much axial force, so much shear, so much moment, etc.

But even a small problem in finite element analysis would generate so many numbers that very few would have the patience to look at all of them – especially if they knew that the stress at a node calculated from the four elements meeting at that node could have four different values, often differing wildly. Not always is the average meaningful or correct; for instance the stress at a node at the junction of a bolt head and its shank, would be compressive from the element in the head, but tensile from the adjacent element in the shank. Here, automation of the averaging process would have not only resulted in murder but also destroyed the

evidence! Selective use of post-processors, particularly graphical representation of displacements and stresses would be very useful; but post-processors, like pre-processors, must be tailored to specific applications, and also require special expertise to develop.

Of course, every one of the obstacles mentioned herein can be overcome, side-stepped, or compensated for, by appropriate counter-measures, and a very reliable answer can usually be extracted. The difficulties have been described in gory detail, only to emphasize the pitfalls of the method, to demonstrate that accuracy cannot be taken for granted even with the best program and the biggest computer, and to highlight the large degree of skill and experience needed in using the method to solve complicated practical problems.

## **8. CONCLUSION**

For engineers interested in applying the finite element method, it is not necessary to know all the theoretical details. But it is essential to know the major assumptions on which the development is based. In any engineering analysis, it is important to know the significance of the approximations built into the methods (and computer programs) used, and the limitations of the analytical models developed. In finite element applications this knowledge can make the difference between a good answer and a bad disaster.

## **REFERENCES**

1. CORUM, J.M. and KRISHNAMURTHY, N. (1969). "A three-dimensional finite element analysis of a prestressed concrete reactor vessel model". Proceedings of Symposium on Application of Finite Element Methods in Civil Engineering, held in Nashville, Tennessee, U.S.A., 63-94.
2. DESAI, C.S. and ABEL, J.F. (1972). Introduction to the Finite Element Method. Van Nostrand Reinhold Co., New York.
3. HUEBNER, K.H. (1975). The Finite Element Method for Engineers. Wiley, New York.
4. KRISHNAMURTHY, N. (1971). "Three-dimensional finite element analysis of thick-walled pipe nozzle junctions with curved transitions". Proceedings of the First International Conference on Structural Mechanics in Reactor Technology, held in Berlin, Germany, Paper G2/7, 213-237.
5. KRISHNAMURTHY, N. (1978). "A fresh look at bolted end-plate behavior and design". Engineering Journal, American Institute of Steel Construction, 15:2, 39-49.
6. KRISHNAMURTHY, N. (1980). "Modelling and prediction of steel bolted connection behavior". Computers and Structures, Pergamon Press 11:1/2, 75-82.
7. KRISHNAMURTHY, N. (1983). "FEABOC: Finite element analysis of bolt connection". Proceedings of Eighth Electronic Computation Conference, American Society of Civil Engineers, held in Houston, Texas, U.S.A., 312-325.
8. LAURSEN, H.I. (1978). Structural Analysis. McGraw-Hill, New York.
9. RUBIN, C., KRISHNAMURTHY, N., CAPILOUTO, E., AND YI, H. (1982). "Stress analysis of the human tooth using a three-dimensional finite element model". Journal of Dental Research, 62:2, 82-86.
10. ZIENKIEWICZ, O.C. (1977). The Finite Element Method, McGraw-Hill, London.